



Speed Sensor Motor Information

GENERAL INFORMATION

White Drive Products speed sensors are non-contact magnetic based devices that can operate in harsh environments with high reliability. They use the latest technology in Hall Effect integrated circuitry to provide separate digital outputs to detect the speed and/or direction of a rotating magnet. They require a magnetic south pole to switch the sensor output from a low (logic "0") to a high (logic "1") and a magnetic north pole to switch from a high to a low signal. These sensors are calibrated to operate symmetrically around zero gauss to provide a 50 % duty cycle. The operating frequency is from 0 to 100,000 Hz. The sensor circuit requires pull-up resistance (i.e. 2K ohm @ 12V- See Example 1) and surge protection . The sensor will operate as low as 5 ma. Reverse polarity protection is built in. The output can be directly interfaced with most rate meters, programmable controllers or TTL/CMOS logic devices. This transducer is an NPN open collector current sinking device. The sensor flange comes equipped with a grease fitting. Filling the sensor cavity with grease provides an additional level of protection for the sen-

sor components in harsh applications. An all-purpose grease is recommended. The sensor flanges may be turned to any position to accommodate the application.

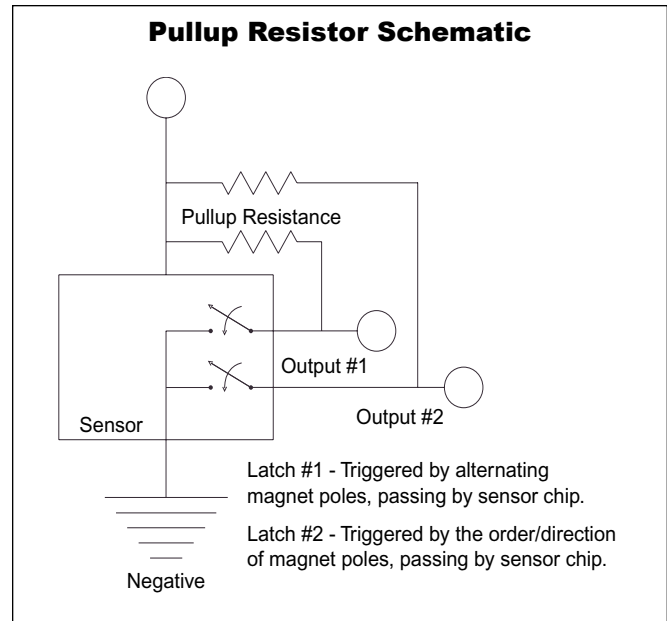

Pullup Resistance Formula*

$$R \text{ (K ohms)} = \frac{V \text{ supply (7.5-18 Vdc)}}{\text{Desired sink current (5-20ma)}}$$

Example: 2K Ohm Resistor = $\frac{12 \text{ V}}{6 \text{ ma}}$

*DO NOT exceed maximum ratings.
 NO pullup resistance destroys sensors.

Example 1

CIRCUIT

Pull-up resistance is required to provide the necessary voltage and current levels to guarantee a "1" logic output whenever the output transistor is in the "off" state. Pullup resistance also limits current through the device and shapes the leading edge of the square wave. Many readouts and controllers have internal pullup resistance available. Follow the device manufacturer's instructions.

Y & Z Option Operating Specifications (Sensor Is Black In Color)

These digital Hall Effect sensors operate at 50 pulses per revolution (ppr) on all series which can accommodate speed sensors except the DT series motors which provides 60 pulses per revolution to produce a square wave signal. Connectors are shown on reverse.

Supply voltages 7.5-24 Vdc
 Maximum output off voltage 24 V
 Maximum continuous output current <25 ma
 Signal levels (low, high)..... .8 to supply voltage
 Operating temperature -22° F to +117° F

W & X Option Operating Specifications (Sensor Is White In Color)

These digital dual element Hall Effect sensors operate at 100 pulses per revolution (ppr) on all series which can accommodate speed sensors except the DT series motors which provides 120 pulses per revolution to produce a square wave signal. Connectors are shown on reverse.

Supply voltages 7.5-18 Vdc
 Maximum output off voltage 18 V
 Maximum continuous output current <20 ma
 Signal levels (low, high)..... .8 to supply voltage
 Operating temperature -22° F to +117° F

Connections

Z

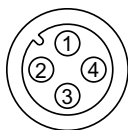

Pin

1	positive	brown or red
2	N/A	white
3	negative	blue
4	pulse out	black

M12 Connector



X

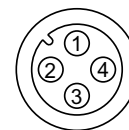

Pin

1	positive	brown or red
2	direction out	white
3	negative	blue
4	pulse out	black

Y

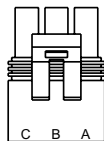

Pin

A	positive	brown or red
B	negative	blue
C	pulse out	black
D	N/A	white

Weatherpack Connector



W

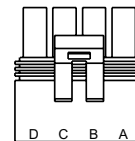

Pin

A	positive	brown or red
B	negative	blue
C	pulse out	black
D	direction out	white

Sensor Testor Schematic

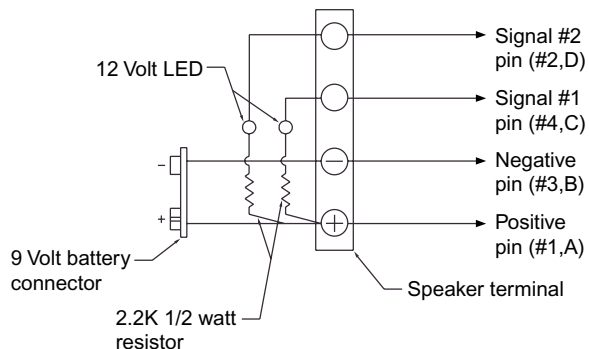

If all components are operating properly, LED #1 will flash each time a pole set passes the sensor and LED #2 will stay on in one direction and stay off when the pole sets are turning in the opposite direction.

Protection Circuitry

The single element sensor has been improved and incorporates protection circuitry to avoid electrical damage caused by:

- reverse battery protection
- overvoltage due to power supply spikes and surges (60 Vdc max.)
- power applied to the outlet lead

The protection circuit feature will help "save" the sensor from damage mentioned above caused by:

- faulty installation wiring or system repair
- wiring harness shorts/opens due to equipment failure or harness damage resulting from accidental conditions (i.e. severed or grounded wire, ice, etc.)
- power supply spikes and surges caused by other electrical/electronic components that may be intermittent or damaged and "loading down" the system

While no protection circuit can guarantee against any and all fault conditions, the single element sensor from White Drive Products with protection circuitry is designed to handle potential hazards commonly seen in real world applications.

Sensor Related Equipment

Tachometers, Counters, and Ratemeters

Red Lion 717-767-6511 **red lion**
www.redlion-controls.com

Cables, M12 Four Pin

Turck 800-588-8725 **TURCK**
euofast 12 mm www.turck.com *WORKS*

White Drive Products is not affiliated with these companies or manufacturers. This partial list has been provided to aid in obtaining speed sensor related hardware.

White Drive Products, Inc. (USA) +1 270 885 1110
White Drive Products GmbH (Germany) +49 2102 123 7770
White Drive Products, Inc. (Hong Kong) +852 2637 6682
White (China) Drive Products Co., Ltd. +86 511 5729988

www.whitedriveproducts.com