



USE EXPLODED VIEW ON BACK FOR REFERENCE

- A) Remove all shaft related components from shaft (34) (i.e. keys, nuts). To aid in reassembly of the motor, make a "V" shaped set of lines from the endcover (31) to the housing (14) using either paint or a marker. With shaft (34) facing down, secure motor in vise by clamping on to housing (14). Loosen and remove four bolts (33) holding motor assembly together. Remove endcover (31) from motor making sure not to drop endcover piston (29). Using needle nose pliers or two small screwdrivers, lift endcover piston (29) out of endcover (31). Remove white Teflon seal (11) and O-ring seal (12) from endcover piston (29) and discard. Remove the piston spring (30) from endcover (31) and lay aside.
- B) Lift commutator container and commutator (28) from motor and lay aside. Place commutator on a flat, clean surface with the seal (10) facing up. Place the tip of a small screwdriver on the seal (10) and gently tap until opposite side of seal lifts from groove. Remove seal (10) and discard.
- C) Remove manifold (27) and rotor assembly (26) from motor. Remove all seals (9) from components and discard. (**Caution - Do not allow rolls to drop from rotor assembly when removing rotor assembly from motor.**) Remove drive link (25) from motor and lay aside.
- D) Put the housing assembly into an arbor press with the shaft facing down. Lower the press to apply downward pressure on the rear housing (23) and lock the press in place. Loosen and remove the eight capscrews (24) holding the rear housing (23) to the front housing (14). Slowly release the press to allow spring pressure to push the rear housing (23) from the front housing (14). Remove the rear housing (23) and lay aside. (NOTE: Bearing (21) and spacer shim(s) (22) may fall out of rear housing (23).)
- E) Remove springs (20) from front housing (14) and lay aside. Remove housing (14) from arbor press and place on a clean, flat surface with output end of shaft (34) facing up. To remove piston (19), friction disks (17) and disk stampings (18), firmly grasp output end of shaft with a rag. Raise housing assembly a few inches above work surface and firmly strike housing assembly on work surface until piston and disks drop from housing assembly. Lay piston (19) and disks (17 & 18) aside. Remove shaft (34) from housing (14) and lay aside.
- F) Remove two thrust washers (15) and thrust bearing (16) from front housing (14) and lay aside. Pry shaft seal (3) and Teflon backup seal (2) from front housing (14) and discard. Remove metal backup ring (1) from front housing (14) and lay aside. Unless the front shaft bearing (13) is damaged, removing it from the front housing (14) is not necessary.
- G) At this point, all parts should be cleaned in an oil-based solvent and dried using compressed air (for safety, observe all OSHA safety guidelines). All new seals should be lightly coated in clean oil prior to installation.
- H) Place shaft (34) on clean work surface with output end of shaft facing up. Place one thrust washer (15) down onto shaft followed by thrust bearing (16) and remaining thrust washer (15). Place shaft seal (3) down onto shaft (34) making sure that lip on seal faces thrust washer (15) (See Figure 1). Place Teflon backup seal (2) onto shaft making sure that lip on seal faces down and fits into recess in shaft seal (3). Place metal backup ring (1) onto shaft making sure that large O.D. side faces Teflon backup seal (2).
- I) With pilot of front housing (14) facing up, lower front housing (14) over shaft and allow front housing (14) to rest on work surface. Grasping output end of shaft (34), place housing/shaft assembly in vise with output end of shaft (34) facing down. Insert a punch down into the center of the shaft and use a hammer to gently tap downwards on the shaft (34) to seat the shaft seal (3) into the front housing (14). Remove punch. Place one disk stamping (18) over shaft O.D. splines and down into front housing (14) followed by one friction disk (17). Repeat process, alternating disks until all disks are installed into housing.
- J) Install small O-ring seal (4) and large O-ring seal (6) into corresponding grooves in piston (19). Install small Teflon seal (5) and large Teflon seal (7) in corresponding grooves over O-ring seals. Thoroughly coat seals and sealing surfaces of housing (14) with clean oil. With large O.D. side of piston (19) facing up, install piston (19) into housing (14) and evenly press piston down making sure not to pinch Teflon seals. (**If friction disks and disk stampings are going to be replaced, the stack up on the new disks must be between .600 and .610. Use FIGURE 3 for measuring reference.**)

- K) Install 25 springs (20) on top of piston. Install O-ring seal (8) in groove in rear surface of housing (14). If rear shaft bearing (21) and spacer shim(s) (22) came out of rear housing (23), reinstall at this time by placing spacer shim(s) (22) into rear housing (23) first followed by rear shaft bearing (21). Place rear housing (23) onto front housing (14) lining up bolt holes. While holding motor assembly together, remove motor assembly from vice and place in arbor press. Press down on rear housing (23) until it contacts front housing (14) and lock press. Install eight capscrews (24) and torque to 45 ft. lbs.
- L) Insert the drive link (25) into the shaft with the tapered end facing up. Place a body seal (9) into the groove in the face of the rotor assembly (26). With the seal side of the rotor assembly (26) facing the rear housing (23), line up the splines of the drive link (25) and the rotor assembly (26) and lower the rotor assembly onto the rear housing (23).
- M) Place a body seal (9) into the groove in each face of the manifold (27). Lift the drive link (25) approximately .100 and place the tip on a small screwdriver under the disk-shaped portion of the drive link to hold it up. Making sure that the notch in the manifold is aligned with the tab on the rotor and that the side with the largest holes faces down, lower the manifold (27) onto the motor and engage the disk shaped portion of the drive link (25) into the groove in the manifold (27) (See Figure 2). Remove the screwdriver and lower the manifold (27). If the disk is engaged in the groove, the end of the drive link will protrude above the surface of the manifold. If it doesn't, remove manifold and repeat this step.
- N) Install the commutator seal (10) into the commutator (28) with the metal side facing out. Use finger pressure to press the seal down flush with the surface of the commutator. Place the commutator container (28) onto the manifold (27) and then place the commutator onto the protruding end of the drive link (25) making sure that the seal side faces up.
- O) Install the remaining body seal (9) in the groove in the face of the endcover (31). Install the piston spring (30) into the endcover (31), then the white Teflon seal (12), followed by the O-ring seal (11). Lining up the alignment pin, press the piston (29) into the endcover (31). While holding the endcover piston (29) into the endcover (31), lower the endcover assembly onto the motor.
- P) Install the four assembly bolts (33) and pre-torque to 10 ft. lbs. Final torque all bolts to 50 ft. lbs.

AUXILIARY VIEWS

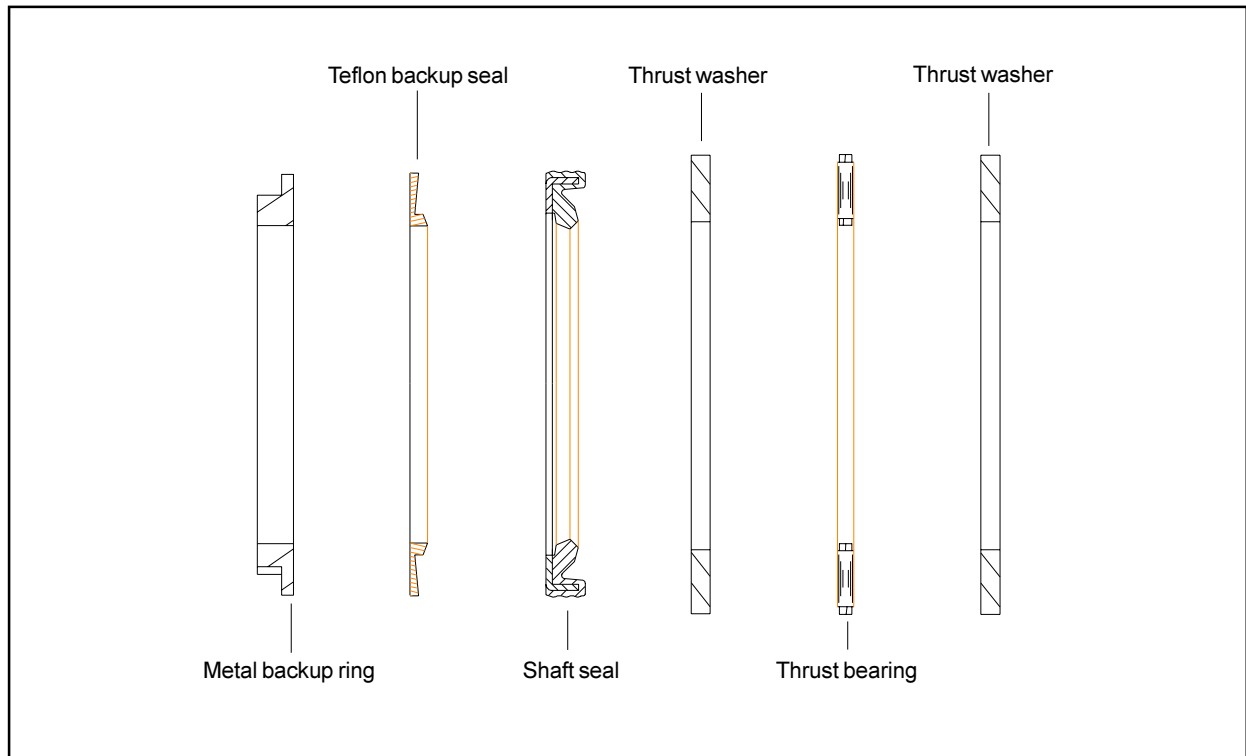

FIGURE 1

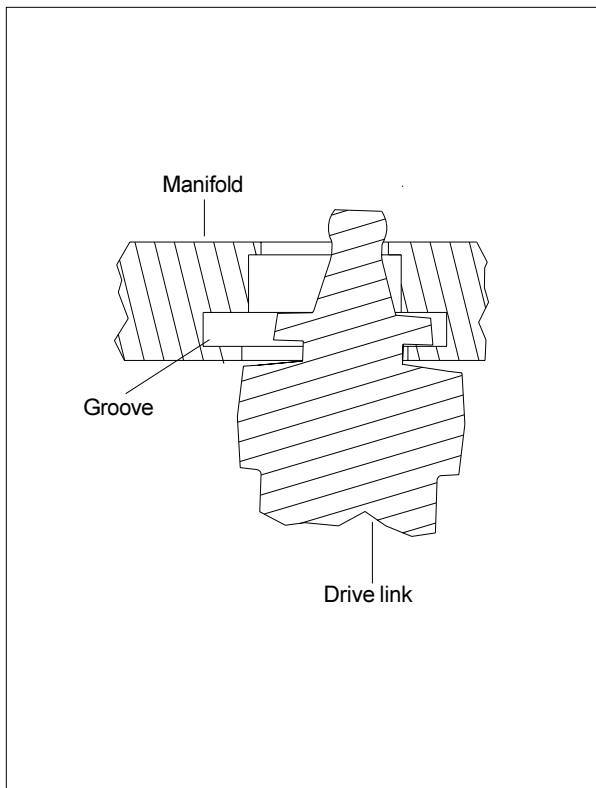

FIGURE 2

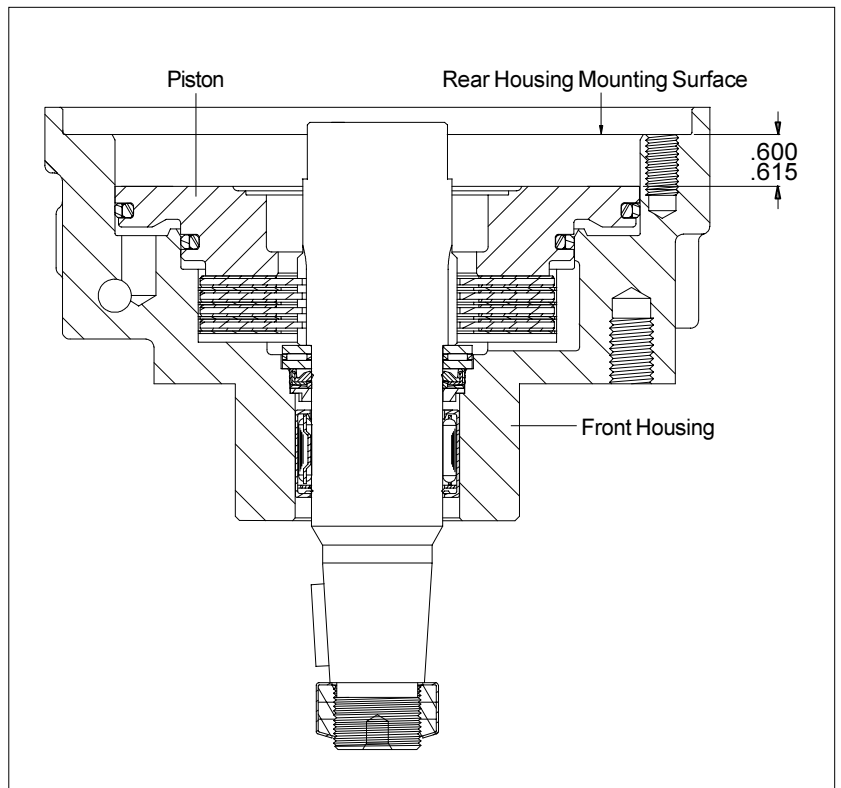
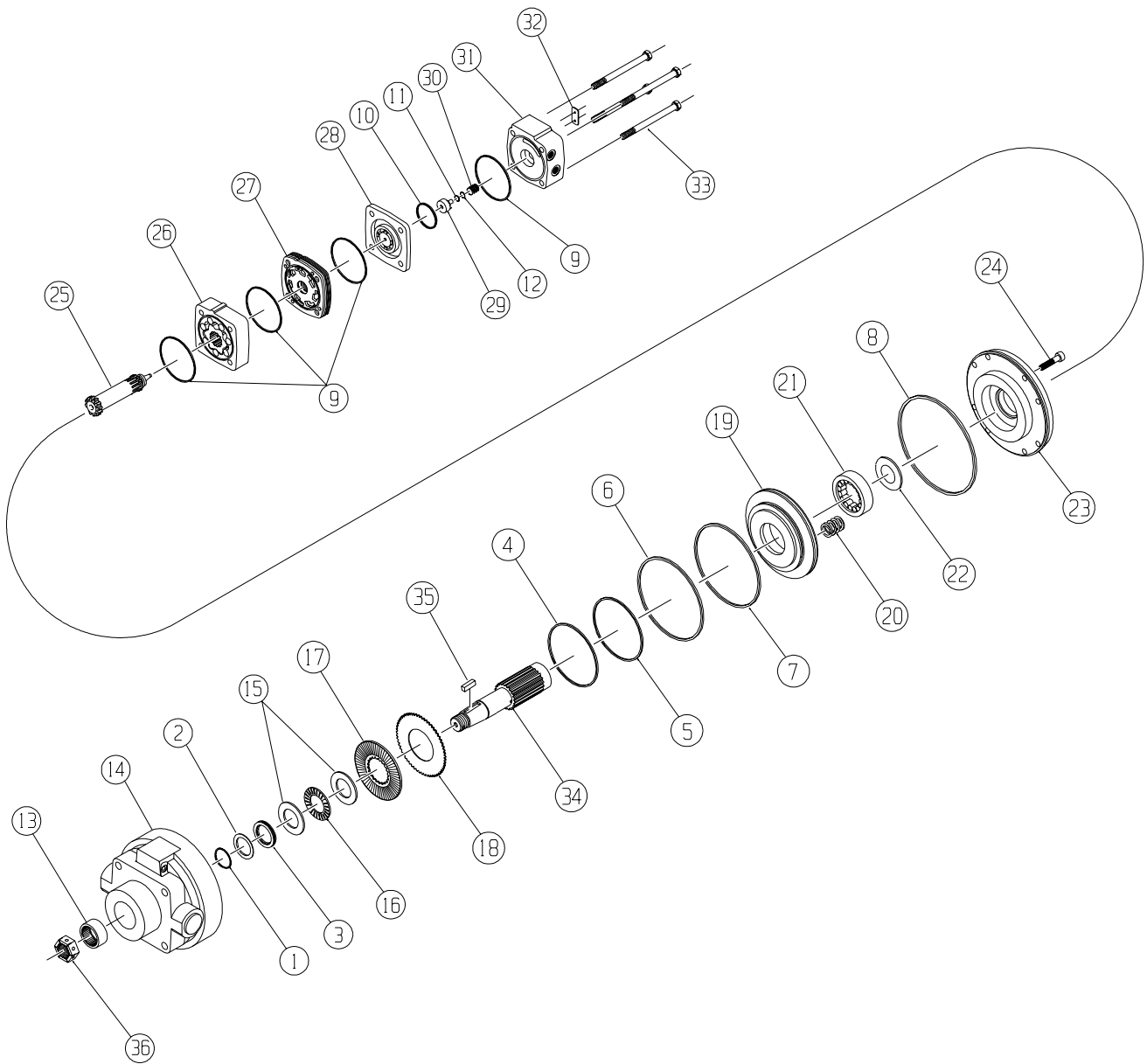

FIGURE 3



HB Brake Motor Components

- | | | |
|------------------------|-------------------------|-------------------------|
| 1. Metal Backup Ring | 13. Front Shaft Bearing | 25. Drive Link |
| 2. Teflon Backup Seal | 14. Front Housing | 26. Rotor Assembly |
| 3. Shaft Seal | 15. Thrust Washers (2) | 27. Manifold |
| 4. Small O-Ring Seal | 16. Thrust Bearing | 28. Commutator Assembly |
| 5. Small Teflon Seal | 17. Friction Disks (4) | 29. Piston |
| 6. Large O-Ring Seal | 18. Disk Stampings (4) | 30. Piston Spring |
| 7. Large Teflon Seal | 19. Piston | 31. Endcover |
| 8. O-Ring Seal | 20. Springs (25) | 32. I.D. Tag Assembly |
| 9. Body Seals (4) | 21. Rear Shaft Bearing | 33. Assembly Bolts (4) |
| 10. Commutator Seal | 22. Spacer Shim(s) | 34. Shaft |
| 11. Piston O-Ring Seal | 23. Rear Housing | 35. Shaft Key |
| 12. Piston Teflon Seal | 24. Capscrews (8) | 36. Shaft Nut |