



BK

SERIES HYDRAULIC BRAKES

BK

OVERVIEW

With safety becoming an increasingly important factor in the design and manufacture of equipment, it has become necessary to add a brake to many critical machine functions. In response to that concern, White Drive Products offers the BK10 Series brake. Based on technology proven in White Drive Products integrated motor/brakes, this spring-applied, hydraulically released brake provides 1130 Nm [10,000 lb-in] of holding torque for static brake applications.

Other features contribute to the superior operation and durability of the brake. All internal components, including roller bearings, brake disks, springs and seals were chosen for maximum durability. To further extend the life of the unit and reduce noise, all internal components run in an oil bath. Two brake release ports are also provided to simplify plumbing and bleeding of the brake release circuit during installation. All of these features combine to make the BK 910 Series brake the top choice for any static brake application requiring 1130 Nm [10,000 lb-in] of holding torque.

SPECIFICATIONS

Holding Torque	1130 Nm [10,000 lb-in]
Release Pressure	28 bar [400 psi]
Maximum release pressure	207 bar [3,000 psi]
Release volume.....	11,5cc [0.7 cu. in.]
Max. Speed	250 rpm
Max. Operating Temperature.....	82°C [180°F]
Weight	16,8 kg [37 lb]
Fluid Type	Mineral based oil

HOUSING

K30 4-Hole 7/16" O-Ring

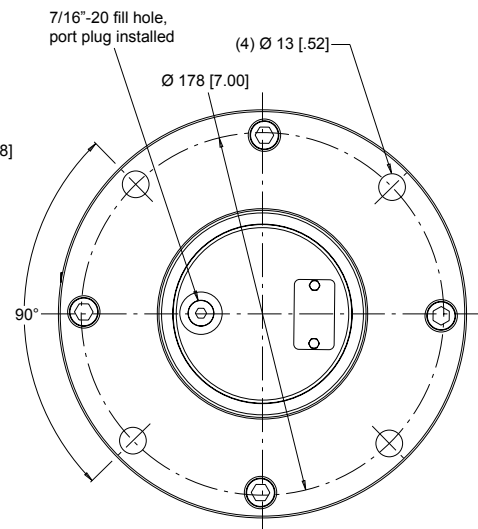
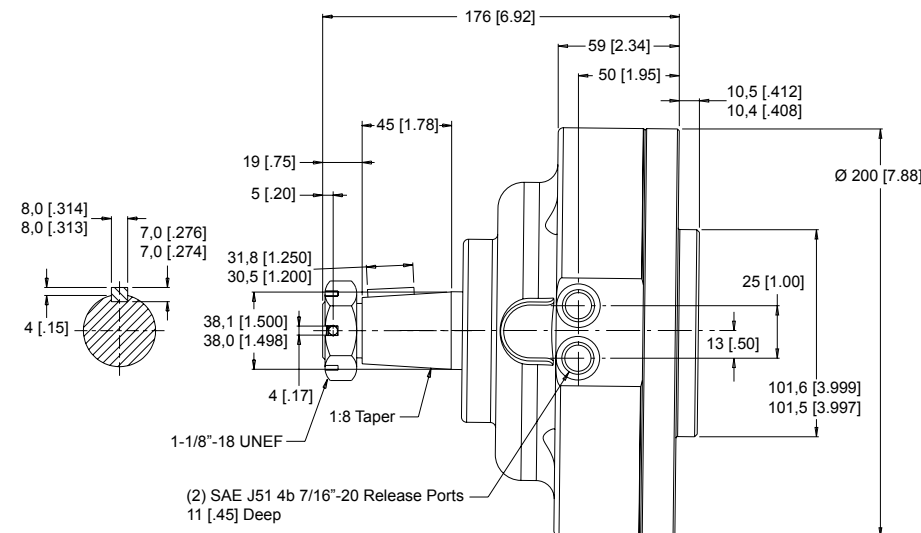

NOTE: Housing shown with the 38,1mm [1-1/2"] shaft. A slotted nut is standard on this shaft. Max. Shaft Torque: 2700 Nm [19900 lb-in]



KEY FEATURES

- Heavy-duty roller bearings** support high shaft loads and provide long life.
- Dual release ports** allow easier bleeding of brake release cavity.
- Oil-filled cavity** immerses all components providing quiet operation and reduced wear.



910 SERIES MODEL CODE BUILDER

Bearing Curve: The bearing curve represents allowable bearing loads based on ISO 281 bearing capacity for an L_{10} life of 2,000 hours at 100 rpm. Radial loads for speeds other than 100 rpm may be calculated using the multiplication factor table located below.

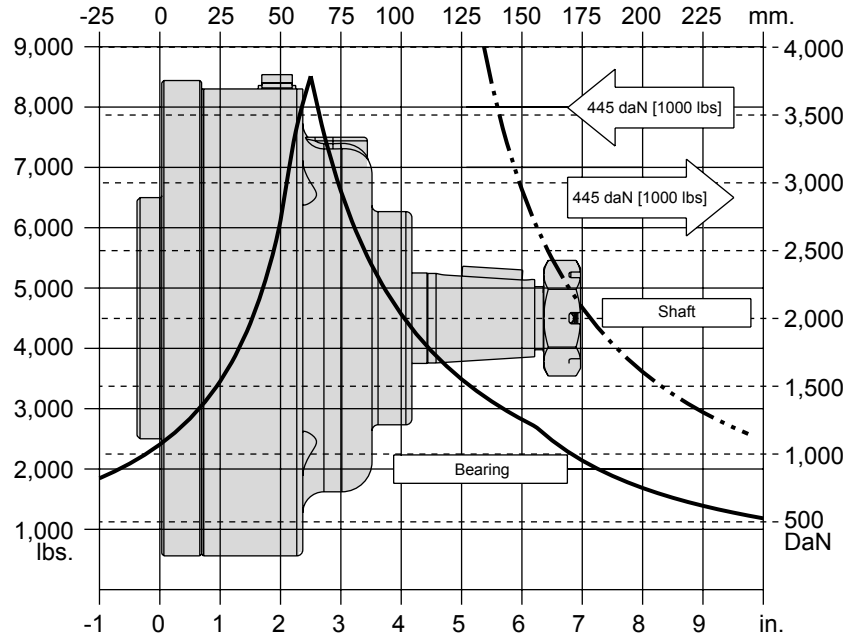

BEARING LOAD MULTIPLICATION FACTOR TABLE

RPM	FACTOR	RPM	FACTOR
50	1.23	500	0.62
100	1.00	600	0.58
200	0.81	700	0.56
300	0.72	800	0.50
400	0.66		

SERIES	DISPLACEMENT	HOUSING	SHAFT	PAINT	CAVITY	ADD ON	MISCELLANEOUS
STEP 1	STEP 2	STEP 3	STEP 4	STEP 5	STEP 6	STEP 7	STEP 8

STEP 1 - Select a series

910 BK Series Brake

STEP 2 - Select a displacement option

000 No Displacement

STEP 3 - Select a mounting option

K30 4-Hole Wheel Mount 7/16" O-Ring Ports

STEP 4 - Select a shaft option

31 1-1/2" Tapered

STEP 5 - Select a paint option

- A Black
- Z No Paint

STEP 6 - Select a valve cavity option

- A None

STEP 7 - Select an add on option

- A Standard
- C Solid Hex Nut

STEP 8 - Select a miscellaneous option

- AA None



Delivering The Power To Get Work Done.

United States

White Drive Products, Inc.
P.O. Box 1127
Hopkinsville, KY. USA 42241
Phone: +1.270.885.1110
Fax: +1.270.886.8462
infousa@whitedriveproducts.com

Germany

White Drive Products GmbH
Mannsnetterstrasse 34
D-88145 Opfenbach, Germany
Phone: +49.8385.924988.0
Fax: +49.8385.924988.9
infoeu@whitedriveproducts.com

China

White (China) Drive Products Co., Ltd.
1-8 Ning Zhen Gong Lu
Zhenjiang, 212021, Jiangsu, China
Phone: +86 511 5729988
Fax: +86 511 5728921
infochina@whitedriveproducts.com



whitedriveproducts

www.whitedriveproducts.com